

MEASURING GAUGE FOR TOOTH ANGLES AND HEIGHT DIFFERENCE **WB 32**

DESCRIPTON OF THE MEASURE INSTRUMENT

The Measuring Gauge for tooth angles and height difference WB 32 (following *Measure Instrument*) is a precision optical-mechanical instrument for checking the cutting geometry of circular saw blades.

This instrument is compact and extremely accurate thereby making it ideal for all applications. The unit is maintenance free and extremely simple to operate.

The measuring instrument is supplied in a practical readiness bag. Against small surcharge you receive a suitable wood case.

Versions

- Type WB 32 Standard (without dial indicator)
- Type WB 32 Universal (special dial gauge with mm-division)
- Type WB 32 Universal Z (special dial gauge with Zoll-division)

TECHNICAL DATA

- Measure range up to 2400 mm of circular saw blade diameters, for tooth pitch 3... 70 mm (Standard version 0 ... 70 mm)
- Stroke 5 mm, for difference measurement
- Measuring surface hardened, ground and hard-chromed
- Steel parts plated to prevent rust and tarnish
- Cylindrical way polished, in self-lubricating, wear-proof bushings
- Guidance ratio 3 x D
- Housing material special precision cast aluminium, anodized
- Angle scale aluminium, black anodized, engraved graduations
- Special dial gauge graduation 1/100 mm or 1/1000 Zoll
- Lens system multielement, with 7 fold magnification, free of distortion
- Vision field of the 18 mm, chromatically corrected magnifying glass
- Weight 520 g (standard version)
585 g (universal / universal Z version)
- Dimensions 115 x 105 x 67 mm

GENERAL INFORMATION

Please observe the notes in these operating instructions, in order that the device will function perfectly and remain operable for a long time.

- Immediately after receipt of the goods that the measuring instrument not damaged and the ordered accessories are present.
- Use the measuring instrument only intended.
- Note the fact that the dial gauge has special translation and therefore only for circular saw blades can be used.
- Make sure during the measurements that the hair cross plate will not damage. If necessary it is available as spare part.

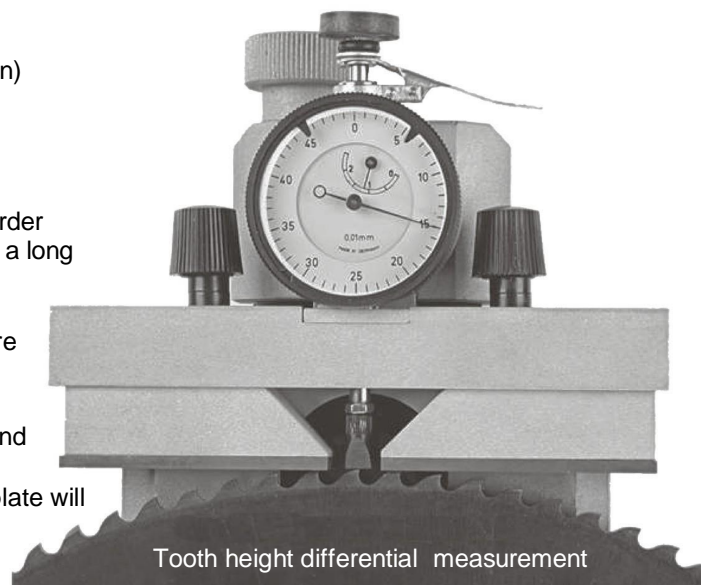
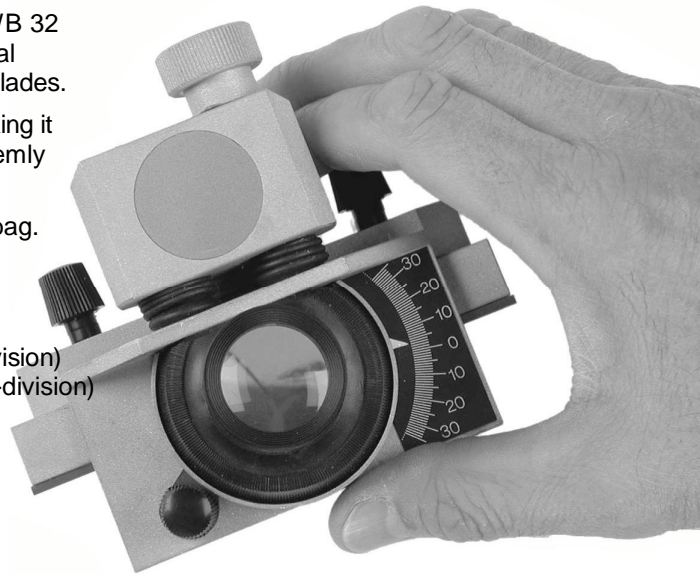

TOOTH GEOMETRY FOR CIRCULAR SAW BLADES

Use of proper tooth geometry assures long blade life and maximum cutting efficiency.

The diagram indicates the normal tooth geometry for circular saw blades.

T Tooth pitch	γ Cutting angle	V Beveled tooth
t Gullet depth	α Clearance angle	N Square tooth
b Gullet diameter	h Tooth height differential	S Tooth face to coolant channel

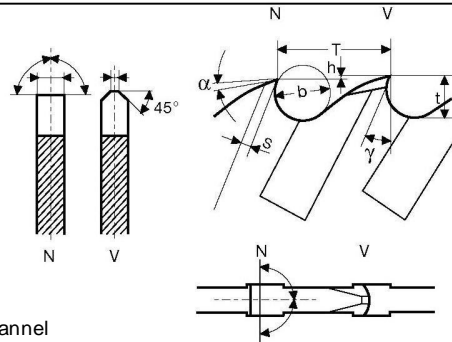

TOOTH ANGLE MEASUREMENTS

All measurements for tooth angles should be taken directly from the square teeth as these are more reliable than when taken from the beveled teeth.

- Measurement should be taken with the blade held in a clock-wise direction, that is, the teeth pointing to the right.
- Place pointer (1) by using lever (2) to the 0 position
- Depress lever (3) of the dial indicator (4) downward to lock the measuring edge (5) in its sup%oosition.
- Loosen knurled nuts (6) and adjust the support bars (7) symmetrically according to the tooth pitch. The symmetry can be checked by observing the markings on the guide track for the knurled nuts.

Note: The tooth to be measured must be properly positioned on the support bar surfaces (7).

- These surfaces must lie on the tips of the beveled teeth. The instrument must then be pushed back so that the blade is against the vertical backing guide.

Caution! Care should be taken not to scratch the cross hair of the lens.

- The tooth shape will now appear in lens (8) magnified approximately 7 times.
- Line up the horizontal cross hair (9) with the top of the tooth using the knurled screw (11).
- Move the instrument sideways until the vertical cross hair (10) lines up with the tooth point.
- Adjust lever (2) until the vertical cross hair (10) lines up with the face of the tooth. (II) Cutting angle γ can now be read on the angle scale (12).
- Adjust lens (2) in a downward direction until the horizontal cross hair (9) is lined up with the top of the tooth (III). The clearance angle α can now be read on the angle scale (12).

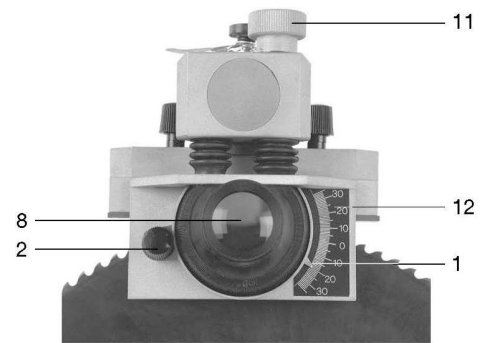

1 Pointer
2 Setting lever
8 Magnifying glass
11 Knurled screw
12 Angle scale

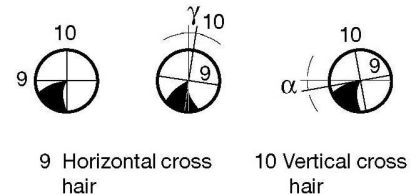

9 Horizontal cross hair
10 Vertical cross hair

MEASURING THE TOOTH HEIGHT DIFFERENTIAL (only WB 32 universal)

- Release lever (3) of the dial indicator (4).
- Place the support bars (7) of the instrument vertically on the tips of the beveled teeth (see illustration).

Caution! Care should be taken not to scratch the cross hair of the lens.

Note: Measuring edge (5) of the dial indicator (4) must be positioned on the top of the square tooth.

- Set the dial indicator (4) in position 0.
- Next place the instrument on the tips of the two square teeth. (7)
- The height differential of the beveled and square teeth can now be read directly on the dial indicator (4).

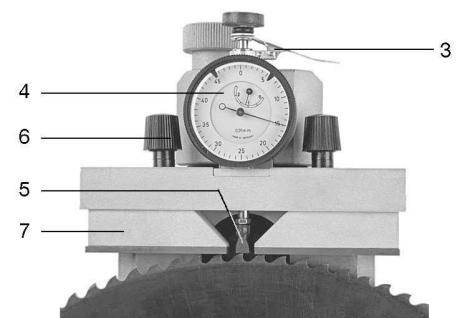

3 Indicator lever
4 Dial indicator
5 Measuring edge
6 Knurled nut
7 Support bars