

MULTI-SPINDLE HEAD - CLASSIC LINE

MULTI H3+

► TECHNICAL DATA

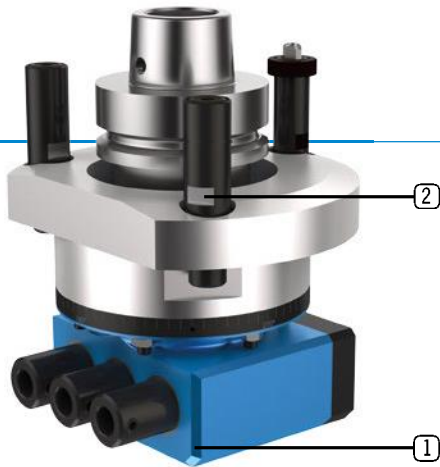

- **Lubrication** Grease
- **Max. drive speed n_2** 10,000 rpm
- **Transmission ratio ($n_1 : n_2$)** 1:1.37
- **Max. drive torque M_2** 5 Nm
- **Weight** about 4 kg

Standard design

1 Spindle distance

25

Output spindle

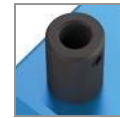

Weldon Ø10

2 Machine connection



HSK - F63



Video



► Multi-spindle head - live in the application

Scan QR code or go to:

[www.youtube.com/
BENZWerkzeugsysteme](http://www.youtube.com/BENZWerkzeugsysteme)

► Specifications

Machining



Number of output spindles

4

Axis angle

90°

C-angle

360°

Lubrication



MULTI H3+

► ADDITIONAL OPTIONS: MODULAR DESIGN

①



► SPINDLE DISTANCE

20

22

22,5

25

25,4

32



Additional spindle distances/ numbers of spindles/ drilling patterns on request

► OUTPUT SPINDLE

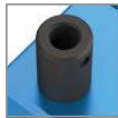

Weldon Ø10



For further information see p. 36

②



► MACHINE CONNECTION



HSK - F63
BIESSE



SK 30
BIESSE



HSK - F63
Busellato



HSK - F63
Felder



HSK - F63
HOMAG / WEEKE / WEINMANN



HSK - F63
IMA



HSK - F63
Masterwood



HSK - F63
SCM



HSK - F63
SCM



HSK - F63
Weinig



For further information see p. 40