

MOULDER HEAD - PREMIUM LINE

MOULDER

► TECHNICAL DATA

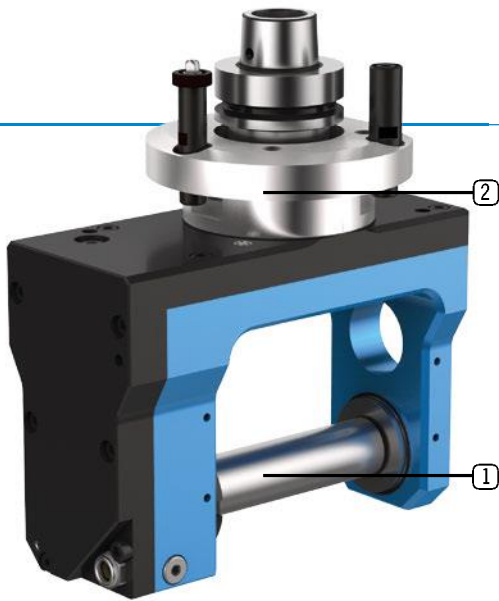

- **Lubrication** Oil bath
- **Max. drive speed n_2** 10,000 rpm
- **Transmission ratio ($n_1 : n_2$)** 1:0.7
- **Max. drive torque M_2** 25 Nm
- **Weight** about 10 kg
- **Max. tool diameter** Ø180

Standard design

① Output spindle

② Machine connection



Arbor Ø30,
tool length
120 mm



HSK - F63



Video

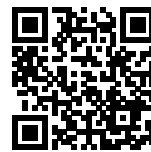

► Unit - live in the application

Scan QR code or go to:

[www.youtube.com/
BENZWerkzeugsysteme](http://www.youtube.com/BENZWerkzeugsysteme)

► Specifications

| Machining | Number of output spindles | Axis angle | C-angle | Lubrication |
|-----------|---------------------------|------------|---------|-------------|
| | | | | |
| | | | | |
| | | | | |
| | | | | |

MOULDER

► ADDITIONAL OPTIONS: MODULAR DESIGN

①



► OUTPUT SPINDLE



Arbor Ø30,
tool length
120 mm



Arbor Ø35,
tool length
120 mm



Arbor Ø35,
tool length
170 mm



Additional arbor diameters and tool lengths on request

②



► MACHINE CONNECTION



HSK - F63
BIESE



SK 30
BIESE



HSK - F63
Busellato



HSK - F63
Felder



HSK - F63
HOMAG / WEEKE / WEINMANN



HSK - F63
IMA



HSK - F63
Masterwood



HSK - F63
SCM



HSK - F63
SCM



HSK - F63
Weinig



For further information see p. 40