

# LOCK RECESS TRIMMING UNIT - CLASSIC LINE

## FORTE

### ► TECHNICAL DATA

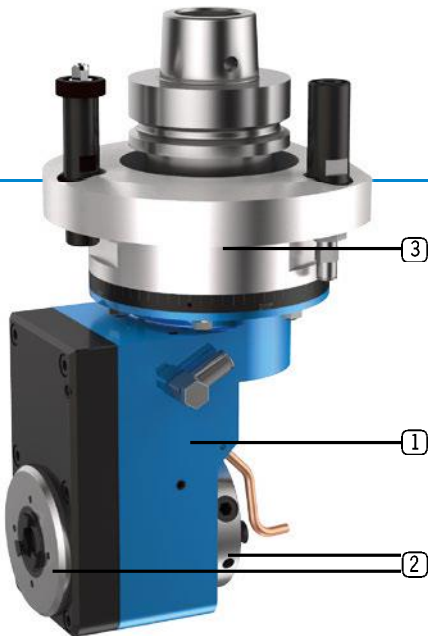

- **Lubrication** Grease
- **Max. drive speed  $n_2$**  15,000 rpm
- **Transmission ratio ( $n_1 : n_2$ )** 1:1.2
- **Max. drive torque  $M_2$**  25 Nm
- **Weight** about 5.5 kg

### Standard design

1 Head length

2 Output spindles

3 Machine connection



Centring Ø30/  
Whistle notch  
Ø16/Ø20



Collet chuck  
ER16A



HSK - F63



Video

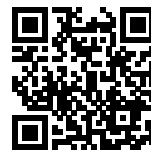

### ► Angle head - live in the application

Scan QR code or go to:

[www.youtube.com/  
BENZWerkzeugsysteme](http://www.youtube.com/BENZWerkzeugsysteme)

### ► Specifications

Machining

Number of  
output spindles

Axis angle

C-angle

Lubrication



FORTE

► ADDITIONAL OPTIONS: MODULAR DESIGN

①



► HEAD LENGTH

M

**i** For further information see p. 38

②



► OUTPUT SPINDLE



Collet chuck ER32



Collet chuck ER16A



Centring Ø40/  
collet chuck ER25A

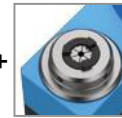

Collet chuck ER16A



Centring Ø30/  
Weldon Ø10



Collet chuck ER16A



Centring Ø30/  
Whistle notch Ø16/Ø20



Collet chuck ER16A



BENZ Solidfix® S3



Collet chuck ER16A



Arbor Ø20,  
tool length 6 - 43mm

**i** For further information see p. 36

③



► MACHINE CONNECTION



HSK - F63 BIESSE



SK 30 BIESSE



HSK - F63 Busellato



HSK - F63 Felder



HSK - F63 HOMAG / WEEKE / WEINMANN



HSK - F63 IMA



HSK - F63 Masterwood



HSK - F63 SCM



HSK - F63 SCM



HSK - F63 Weinig

**i** For further information see p. 40