

CORNER NOTCHING UNIT - CLASSIC LINE

ANGULO

► TECHNICAL DATA

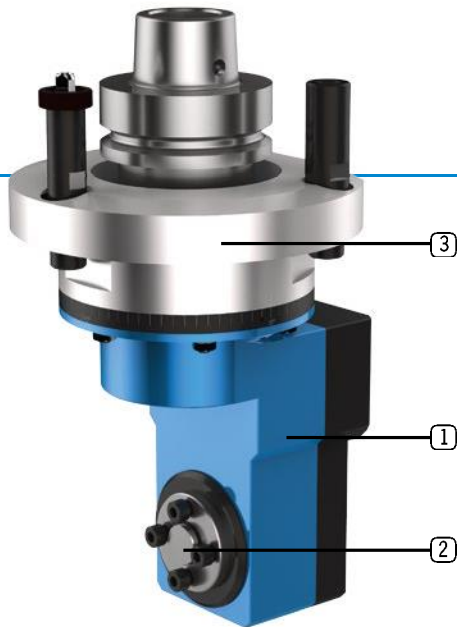

- **Lubrication** Grease
- **Max. drive speed n_2** 10,000 rpm
- **Transmission ratio ($n_1 : n_2$)** 1:1.3
- **Max. drive torque M_2** 20 Nm
- **Weight** about 4.5 kg

Standard design

1 Head length



2 Output spindle



Centring Ø16

3 Machine connection



HSK - F63



Video



► Angle head - live in the application

Scan QR code or go to:

[www.youtube.com/
BENZWerkzeugsysteme](http://www.youtube.com/BENZWerkzeugsysteme)

► Specifications

Machining



Number of
output spindles



Axis angle



90°

C-angle



360°

Lubrication



ANGULO

► ADDITIONAL OPTIONS: MODULAR DESIGN

①



► HEAD LENGTH



i For further information see p. 38

②



► OUTPUT SPINDLE



Collet chuck
ER16A



Collet chuck
ER25M



Centring Ø16

i For further information see p. 36

③



► MACHINE CONNECTION



HSK - F63
BIESSE



SK 30
BIESSE



HSK - F63
Busellato



HSK - F63
Felder



HSK - F63
HOMAG / WEEKE / WEINMANN



HSK - F63
IMA



HSK - F63
Masterwood



HSK - F63
SCM



HSK - F63
SCM



HSK - F63
Weinig

i For further information see p. 40